

INSTALLED INSTRUCTION
AR-0300M
ELECTROMAGNETIC LOCK

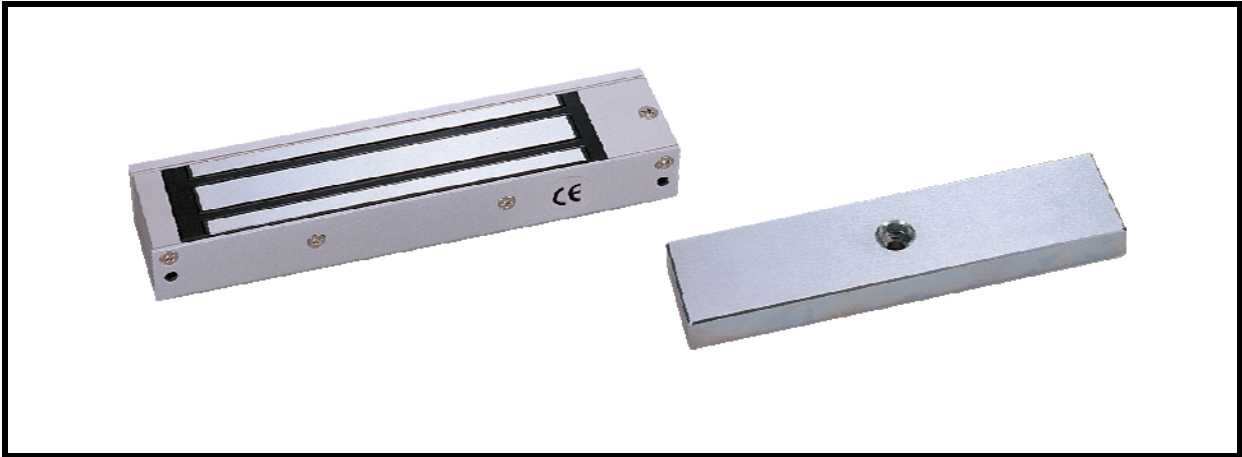

► SPECIFICATION

DESCRIPTION	SINGLE ARMATURE
	AR-0300M
Door monitoring output (reel sensor NO/NC)	⊙
Input Voltage	12 to 24 VDC
Current Draw	12VDC - 370mA 24VDC - 185mA
Holding Force	300LBS (150KG)
Dimensions(L x W x D)	
Surface magnet	166 x 38.5 x 21 mm
Strike plate	130 x 32 x 10 mm
Material Armature housing	Aluminum

OUT SWING DOOR ASSEMBLY

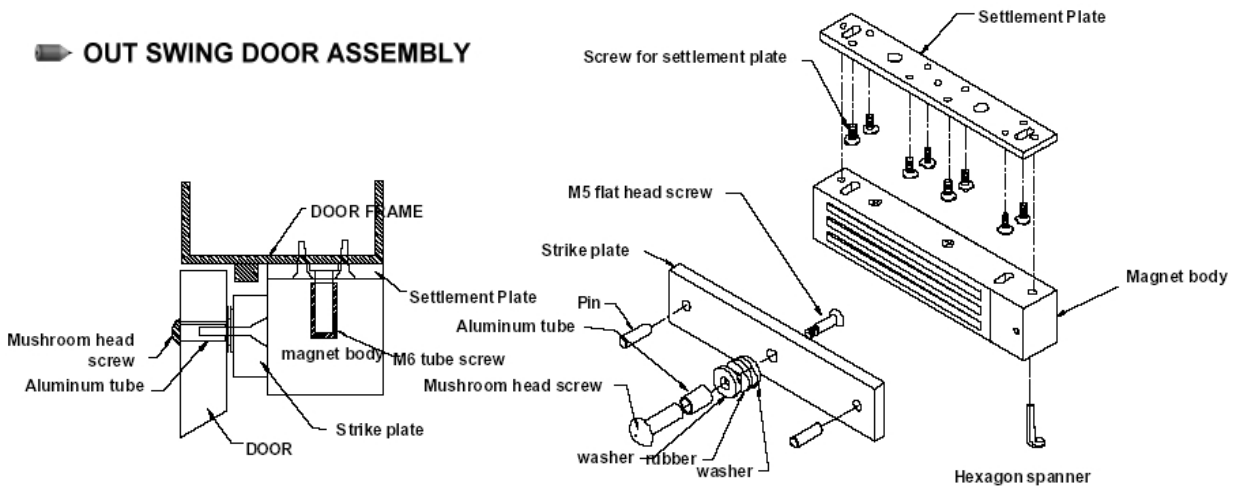

1. Use 9 screws for settlement plate to fix the strike plate and magnet body on the door frame tightly.
2. Make sure the strike plate position, drive a hole on the door by the size of M5 flat head screw at the center position of strike plate (To fit mushroom head screw and aluminum tube). Insert 2 pin at the two side of strikeplate. At the same position of 2 pins, drive match holes (5~6mm diameter) on the door.
3. Between strike plate and door, install 2 washers and 1 rubber in the middle of two washers. Behind the door, insert aluminum tube (length depends on the door thickness). Use mushroom head screw to lock strike plate on the door. Note: Make sure the plate can be slightly shaken when locked. This will have better conjunction to the magnet body and reach the best efficiency.

IN SWING DOOR ASSEMBLY

IN SWING DOOR ASSEMBLY

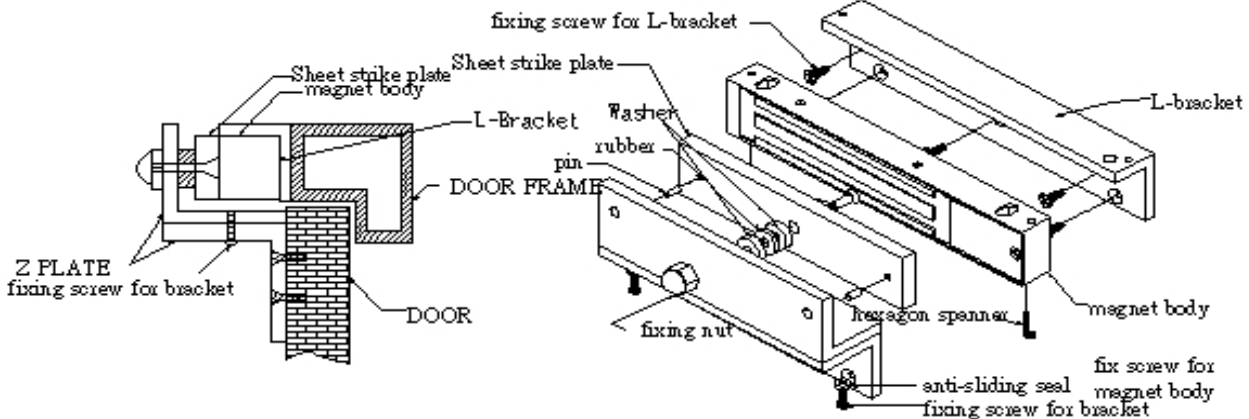

1. According to the door frame location set the approximate position of the L-bracket on the door frame. Use the 5 fixing screws to fix the L-bracket tightly on the door frame. Use M4 screws to lock the magnet body with the L-bracket.
2. Accommodate the strike plate to the Z-bracket, lock to the door. Make sure it is at relative position to the magnet body. The Z-bracket fixing-screw can adjust forward or backward to make the distance between magnet body and strike plate properly when door close then lock the Z-bracket fixing-screw tightly. Note: To prevent sliding status, Z-bracket fixing-screw must accommodate with anti-sliding washer.
3. There must have 2 washer and 1 rubber between strike plate and Z-bracket. Put rubber between 2 washers. Lock the M8 flat head screw on th middle of strike plate will have better conjunction to the magnet body and rech the best efficiency.