

INSTALLED INSTRUCTION

AR-1500WF

ELECTROMAGNETIC LOCK



SPECIFICATION

DESCRIPTION	AR-1500WF
Door monitoring output (reel sensor NO/NC)	⊙
Input Voltage	12 to 24 VDC
Current Draw	12VDC - 500mA 24VDC - 250mA
Holding Force	1300LBS
Dimensions (L x W x D)	
Surface magnet	203 x 63 x 42 mm
Strike plate	185 x 61 x 16 mm
Material	
Armature housing	Stainless steel
Strike plate	Steel

IN SWING DOOR ASSEMBLY

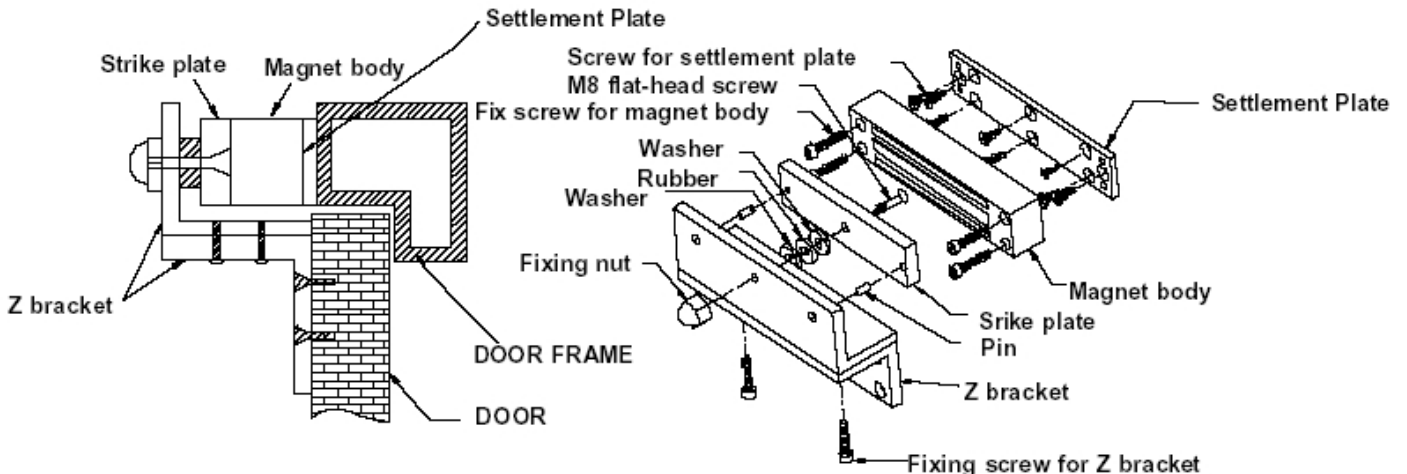

1. Locate the desired position on the doorframe and attach the settlement plate to this location, using 8 screws included in the package.
2. Insert 4 included screws through the pre-drilled holes on the lock and screws tightly to the settlement plate.
3. Locate the proper position on the door, when closed, the magnetic lock will align correctly with the doorframe. Drill 5 holes at this location and attach the Z bracket to it. Important remark for tightening the Z bracket, tightening screws must be accompanied by a spring-washer to avoid slippery.
4. Insert the 2 pins to the strike plate, place a pair of washers separated by rubber and between the strike plate. Insert the M8 flat head screw through the center of the strike plate, pass through the washers and tighten it to the Z bracket. Do not install the strike plate with Z bracket too tight. Leave some space to allow for best performance between the plate and lock.

ELECTRICAL INSTALLATION

